

2025



BOLLINGER B4 QUICK REFERENCE GUIDE

BOLLINGER MOTORS

TABLE OF CONTENTS

1.	SAFELY ENTERING & SITTING IN THE CAB	2
2.	DRIVER CONTROLS OVERVIEW.....	3
3.	INSTRUMENT PANEL TELLTALES	5
4.	VEHICLE OPERATION	6
5.	CAB TILT	7
6.	BATTERY CHARGING WARNINGS & CAUTIONS	8
7.	HIGH VOLTAGE BATTERY CHARGING CONNECTIONS & TIMES.....	9
8.	HIGH VOLTAGE BATTERY CHARGING.....	10
9.	LOW VOLTAGE BATTERY CHARGING	11
10.	CHECKING FLUIDS.....	12
11.	HIGH VOLTAGE IDENTIFICATION	13

1. SAFELY ENTERING & SITTING IN THE CAB

CAUTION: DO NOT use the steering wheel to pull yourself in, as doing so could result in wear and damage to the steering wheel and steering column.

1. Open the driver door.

2. Using the door assist handle, the cab assist handle, and the footstep as your 3-points of support, step up into the cab while pivoting to the seated position.



3. While sitting in the seat, pull up on the seat adjust handle and slide the seat forward or rearward so you can comfortably reach all controls. Release the bar once you have reached the desired position.

Note: The manual seat adjustment handle is located under the seat cushion at the front edge of the driver seat.

4. With the seat adjust handle released, attempt to move the seat forward and rearward to be sure that the seat adjusters have latched.



CAUTION: Adjusting a seat while driving is dangerous. Moving a seat while driving could result in loss of control which could cause a collision and serious injury or death.





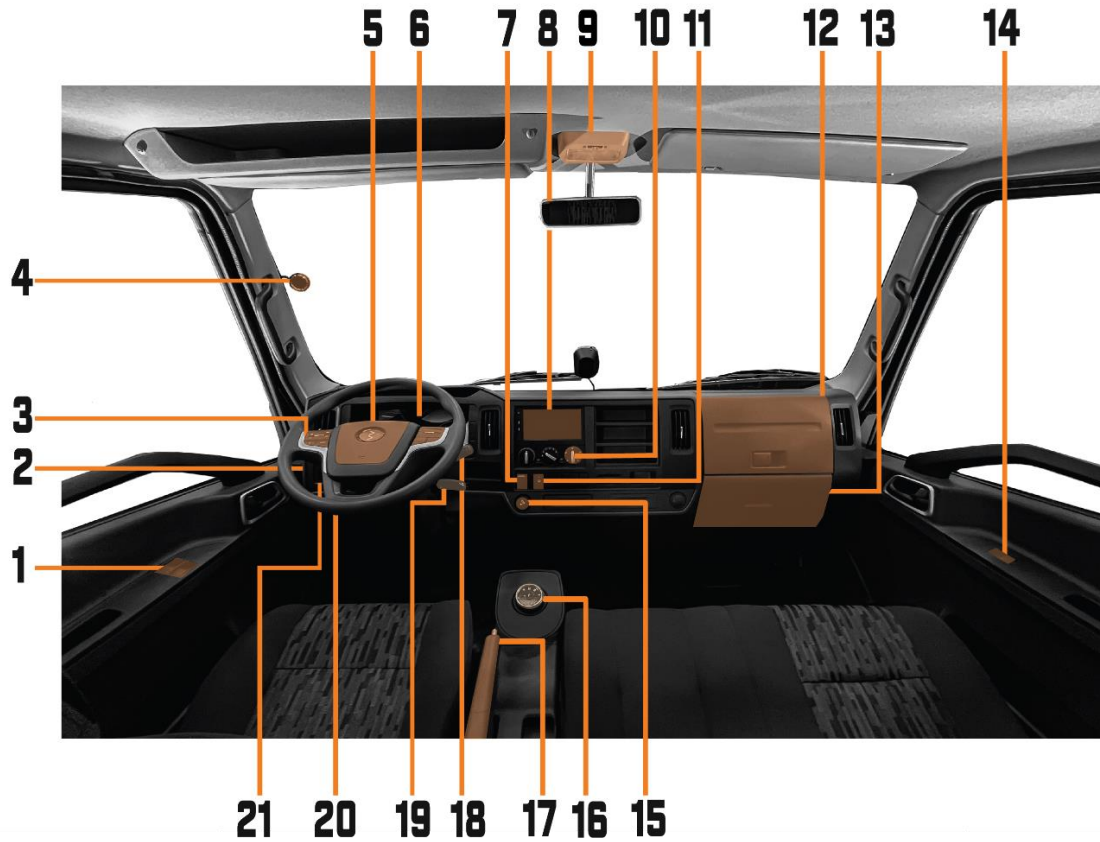















CAUTION: Seats should be adjusted before fastening the seat belts and while the vehicle is parked. Serious injury or death could result from a poorly adjusted seat belt and/or seat adjustment.

2. DRIVER CONTROLS OVERVIEW



1. Driver Power Window Switch	11. PTC Heater Switch
2. Interior Lights Switch	12. Upper Stowage Compartment
3. Steering Wheel Radio & Mode Control Switch	13. Lower Stowage Compartment
4. Mobileye (if equipped)	14. Passenger Power Window Switch
5. Horn Pad	15. Cigarette Lighter / 12V Accessory Outlet
6. Instrument Cluster	16. Drive Selector
7. Hazzard Flashers Switch	17. Parking Brake Lever
8. Center Display	18. Windshield Wiper & Washer Stalk
9. Dome Lamp	19. Ignition Switch
10. HVAC Controls	20. Tilt / Telescopic Steering Column Lever
	21. Multi-function Turn Signal Lever

3. INSTRUMENT PANEL TELLTALES

Indicator	Color	Description	Indicator	Color	Description
	YELLOW	Low battery. Battery charge is lower than 20%. Charge the Battery.		GREEN	ECO mode on (If Equipped).
	YELLOW	Battery power limited. Driving power is limited. Charge the Battery.		GREEN	Cruise control on.
	RED	Motor malfunction. <i>See your authorized Bollinger Motors Dealer or Service Provider.</i>		YELLOW	Electric Power Take Off (ePTO) active (If Equipped).
READY	GREEN	Vehicle ready to drive.		YELLOW	Vehicle speed limited (If Equipped).
	RED	Malfunction Indicator. <i>See your authorized Bollinger Motors Dealer or Service Provider.</i>		RED	Driver seat belt not buckled.
PARK	RED	Parking brake applied.		GREEN	Low beam head lamps on.
	RED	Battery Malfunction. <i>See your authorized Bollinger Motors Dealer or Service Provider.</i>		BLUE	High beam head lamps on.
BRAKE	RED	Brake System Malfunction. <i>See your authorized Bollinger Motors Dealer or Service Provider.</i>		GREEN	Running lights / parking lights on.
ABS	YELLOW	ABS System Malfunction. <i>See your authorized Bollinger Motors Dealer or Service Provider.</i>		GREEN	Left turn.
	GREEN	Charging. Vehicle is plugged in and charging.		GREEN	Right turn.
	RED	Electronic Brake System Malfunction (If Equipped). <i>See your authorized Bollinger Motors Dealer or Service Provider.</i>		GREEN	Front fog lamps on.
	YELLOW	Electric Power Steering Malfunction. <i>See your authorized Bollinger Motors Dealer or Service Provider.</i>	EBD	RED	Electronic Brake Distribution Malfunction. <i>See your authorized Bollinger Motors Dealer or Service Provider.</i>
	RED	Cab Ajar (If Equipped). Latch cab.		YELLOW	T-Box Failure (If Equipped).

4. VEHICLE OPERATION

Starting the Truck:

1. Fasten the seatbelt.
2. Verify parking brake (A) is engaged and the drive selector (D) is in PARK (P) or NEUTRAL (N). Depress the brake pedal (C).
3. Insert key into ignition (B) & turn it to the START position.
4. The **READY** indicator will illuminate indicating that the vehicle is operational.
5. Allow key to return to the RUN position.

Driving the Truck:

1. Adjust your seat and mirrors to allow for maximum visibility and comfort.
2. While keeping your foot on the brake pedal (C), depress the parking brake lock button and lower the parking brake lever (A).
3. Rotate the drive selector (D) to the DRIVE (D) or REVERSE (R) position. **Note:** *The drive selector rotary dial will return to its starting position once released after selecting the drive state desired. To transition from drive to reverse, the drive selector must be rotated and held momentarily until it indicates REVERSE (R).*
4. Check your surroundings and slowly let your foot off the brake pedal.

Returning to Park:

1. Bring the vehicle to a complete stop.
2. Apply the parking brake by pulling the parking brake lever (A) up.
3. Rotate the drive selector (D) to NEUTRAL (N).
4. Press the PARK (P) button in the drive selector (D).

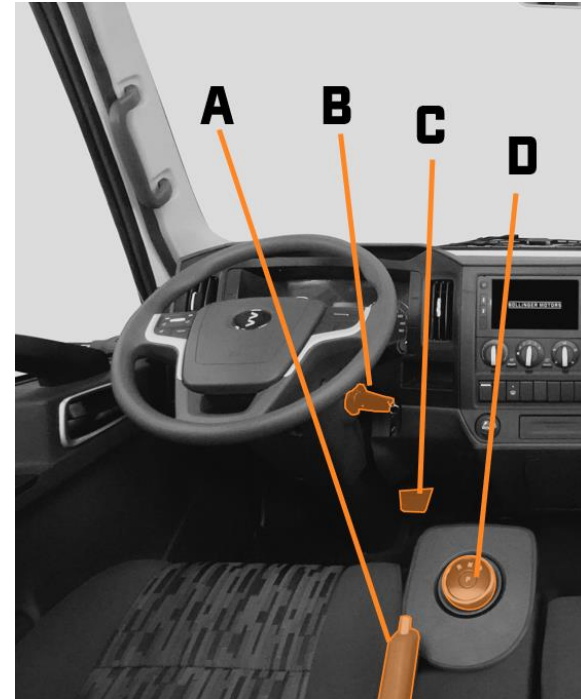

5. CAB TILT

WARNING: To help avoid personal injury when tilting cab follow the directions below:

1. Park the vehicle on level ground and ensure ample space around the cab before commencing this operation.
2. Set the parking brake firmly and block the front wheels with proper wheel blocks.
3. Ensure “P” (Park mode) is engaged.
4. Remove all objects from the instrument panel, seat, and cab floor.
5. Be certain the cab doors are closed.
6. Always insert the lock pin into the cab support when the cab is in raised position.
7. Make sure the lock hood attached to the handle has been firmly engaged.

To Tilt Cab:

1. On the driver side, place your left hand, palm up, on the cab tilt handle (D) and pull the cab tilt lock safety release (A) toward you.
2. With the cab tilt lock safety release disengaged, with your right hand lift the cab tilt release lock (C) lever (rotating clockwise) to release it from the cab tilt latch receiver.
3. Stabilize the cab by grasping the cab tilt handle (D) with your left hand, grasp the cab tilt release (B) and pull the handle toward you to release the cab fully and tilt it forward.
4. Raise the cab to its full lift position and ensure the cab tilt support arm (E) is fully locked.
5. Insert the lock pin (G) into cab tilt support arm (E).

Note: To lower cab reverse procedure.

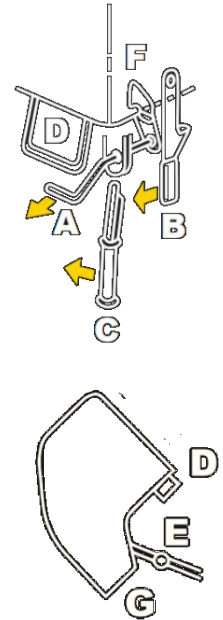

6. BATTERY CHARGING WARNINGS & CAUTIONS

WARNING: Follow the high voltage charger instructions provided by the charger manufacturer.

WARNING: Do not connect a low voltage charger while a high voltage charger is already connected. Disconnect the high voltage charger prior to connecting the low voltage charger.

WARNING: Electric shock occurs when the human body becomes a part of the electrical circuit, causing the current to enter at one point and leave at another. Contact with a current as low as 6mA can cause serious injury or death, and a 6mA current is likely to occur when both the high and low voltage chargers are plugged in at the same time.

WARNING: An arc flash is an uncontrolled release of incident energy typically lasting less than one (1) second where electricity travels across a circuit gap resulting in blinding light and extreme heat, which could cause serious injury or death.

WARNING: A concussive pressure wave is caused by an arc fault and is often loud and accompanied by ejected hot shrapnel and metallic vapors, which could cause serious injury or death.



CAUTION: Arc flashes and arc faults are caused by the following: Material failure, loose connections and exposed live parts, dust, faulty installation, corrosion, condensation, intrusion from animals, and other possible causes.

CAUTION: Before charging the vehicle, the drive selector should be in the PARK position, with the park brake engaged, the ignition switch in the OFF position, and the key removed.

CAUTION: All chargers must comply with J1772 CCS AC & DC Plug requirements, as described by the charger manufacturer.

7. HIGH VOLTAGE BATTERY CHARGING CONNECTIONS & TIMES

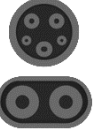
Approximate Charge Duration	From 0% State Of Charge (SOC) To 100% SOC
Level 2	9 hours @ 19.2KW
DC FAST CHARGE	2 hours @ 110KW

Charge Connection Connector Types	
Charge Port	
IEC Type 1	
CCS 1	

- A. High voltage service cut-off switch
- B. High voltage vehicle charging port
- C. 12V positive and negative charge port posts

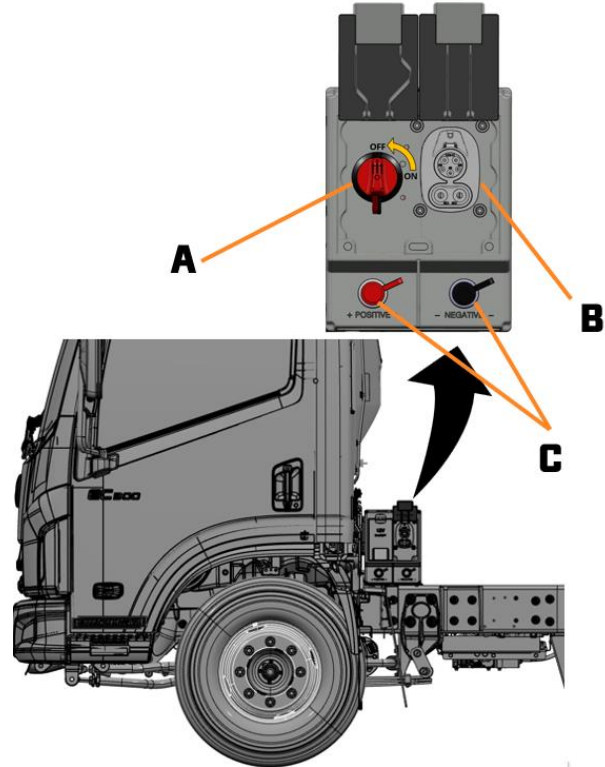

8. HIGH VOLTAGE BATTERY CHARGING

Note: If the vehicle is exposed to temperatures of 14°F (-10°C) or below for 8 hours or more, the vehicle must be connected to a charger to maintain vehicle performance.

Note: If the vehicle is expected to be stored for an extended period, the high voltage system should be disabled by switching the high voltage Service Cut-Off Switch (A) to the OFF position.

1. Turn the ignition to the OFF position.
2. Inspect the charging cable, connectors, and adaptor connector for wear or damage. Ensure that a positive connection can be made and that connector the ports are free of corrosion, moisture, or debris. Ensure that the vehicle-side charging adapter is attached to the charging cable and that the charging cable is attached to the charger.
3. Open the high voltage vehicle charging port door by gently raising it up and open.
4. Insert the charging plug assembly into the high voltage vehicle charging port (B) and ensure there is a good connection by feeling and hearing the 'click'.
5. Switch the charger on.

Note: The charging indicator located in the Instrument cluster should illuminate green. 

6. Charging will automatically stop once batteries reach optimal capacity.
7. Remove and stow cable and close vehicle charge port door once charging has completed.

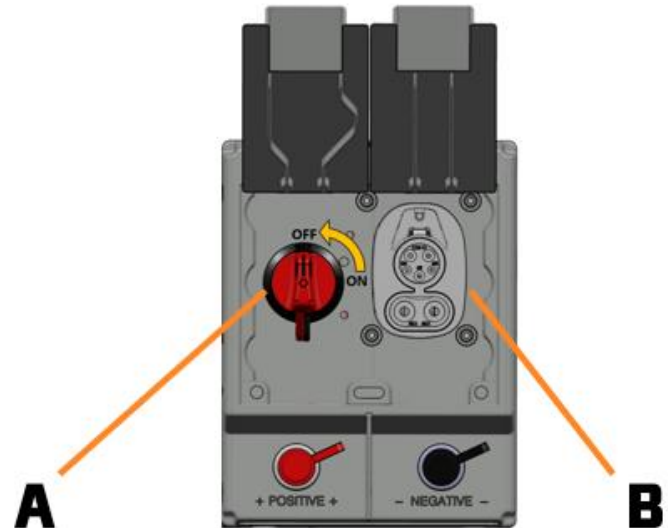

9. LOW VOLTAGE BATTERY CHARGING

1. Turn the ignition to the OFF position.
2. Locate the red high voltage Service Cut-Off Switch (A) located behind the cab on the driver side.
3. Turn the high voltage Service Cut-Off Switch (A) to the “OFF” position.
4. Connect the charger to the positive and negative charge port posts (B) and charge the battery.
5. Once fully charged, turn off and disconnect the low voltage battery charger.
6. To operate vehicle, turn the high voltage Service Cut-Off Switch (A) to the “ON” position.

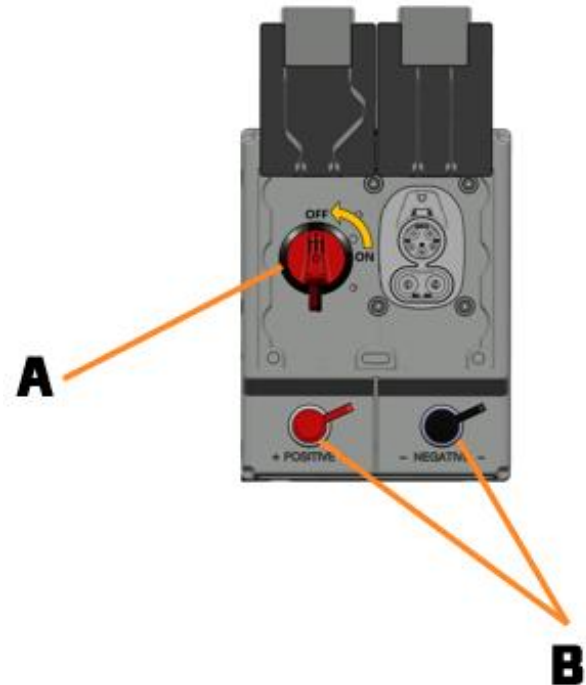

10.CHECKING FLUIDS

WARNING: Operating, servicing, and maintaining this vehicle can expose you to chemicals, which are known to cause cancer, birth defects, or other reproductive harm. For more information go to www.P65Warnings.ca.gov/passenger-vehicle.

1. Open the driver door.
2. Remove the brake fluid reservoir dash cover panel.
3. Inspect the fluid.



Brake Fluid

1. Open the passenger door.
2. Remove the washer fluid reservoir dash cover panel.
3. Inspect the fluid.

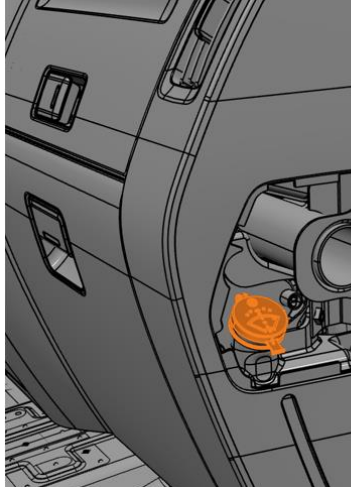

Windshield Washer Fluid

1. Tilt the Cab. See **CAB TILT**.
2. Inspect the fluid.

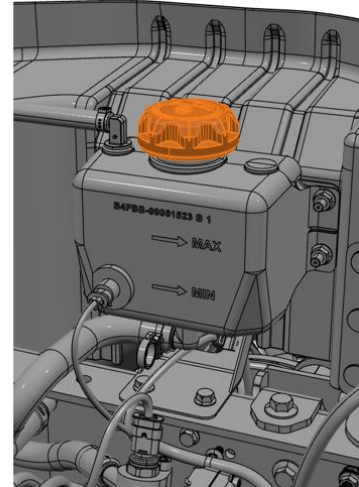

Coolant

11. HIGH VOLTAGE IDENTIFICATION

WARNING: To prevent the risk of high voltage shock, precisely follow all warnings, and instructions to disable the high voltage system. Failure to follow these instructions may result in serious injury or death.

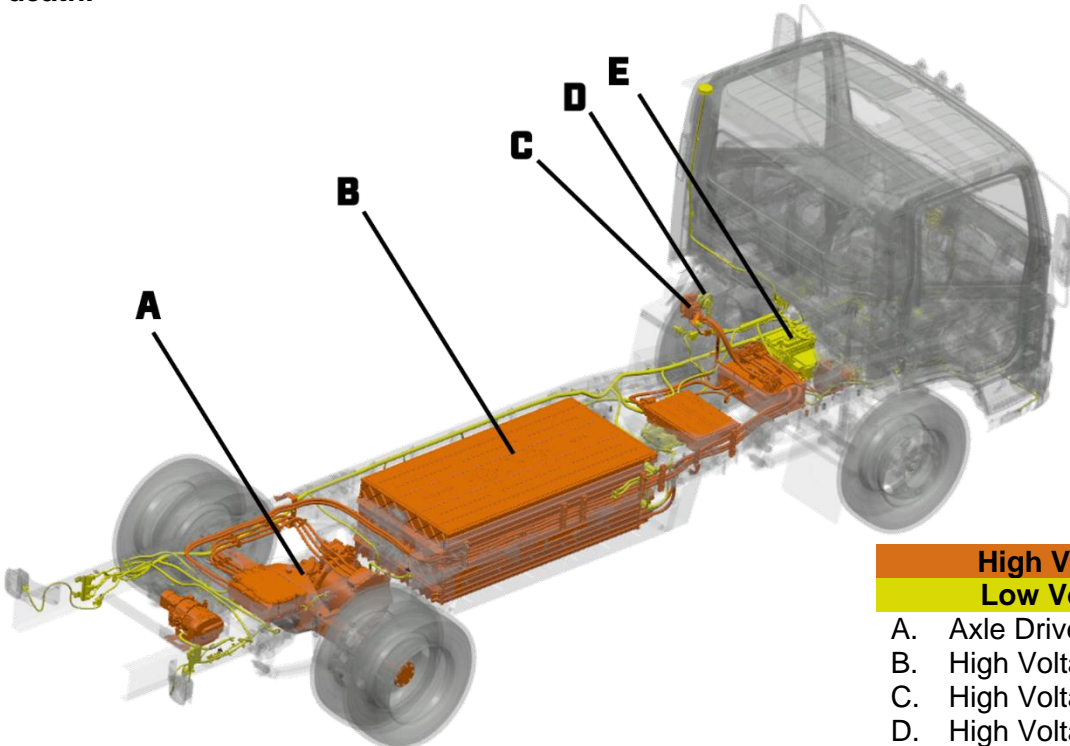

High Voltage Components

Low Voltage Components

- A. Axle Drive Assembly
- B. High Voltage Battery
- C. High Voltage Vehicle Charging Port
- D. High Voltage Service Cut-Off Switch
- E. 12V Battery

PART NUMBER/SKU

FIRST EDITION 25_B4_QRG_EN_US

SCAN FOR THE MOST UP-TO-DATE INFORMATION

or visit
bollingermotors.com



©2024 Bollinger Motors, Inc. All Rights Reserved.
BOLLINGER MOTORS is a registered trademark of Bollinger Motors, Inc.

